

Polarization Insensitive Isolator Core

Features

High Isolation
 Low Insertion Loss
 Low PDL
 Low PMD

Applications

Faraday Rotator Based Component for In-line Fiber Optic Isolator
 Integrate with Other Components to Block Back Reflection
 Enhance Device Isolation

Specifications

Parameters	Unit	Values			
		Single Stage	Dual Stage	Single Stage	Dual Stage
Center Wavelength	nm	1310 or 1550		1064	
Operating Wavelength Range	nm	±20		±5	
Typ. Peak Isolation	dB	42	52	38	52
Min. Isolation at 23°C	dB	40	50	35	48
Max. Insertion Loss at 23°C	dB	0.12/0.15 ¹	0.25	1.0	2.0
Max. PDL at 23°C	dB	0.05	0.05	0.05	0.1
Max. PMD	ps	0.2/0.05 ¹	0.05	-	-
Max. Optical Power (CW)		300			
Max. Tensile Load	N	5			
Operating Temperature	°C	-5 to +70		-5 to +50	
Storage Temperature	°C	-40 to +85			

¹For PMD Compensated Version.

Package Dimensions

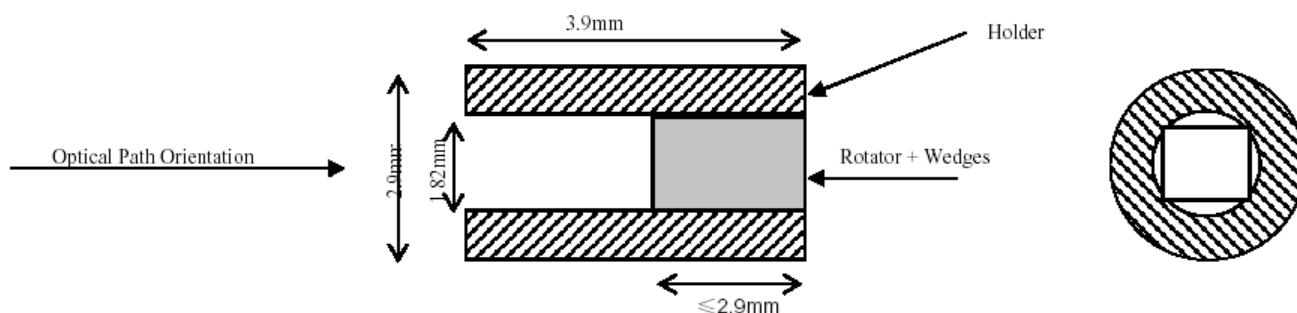

Ordering Information

APIIC-①①-②-③-④

①①: Wavelength

06 - 1064nm

55 - 1550nm

31 - 1310nm

SS - Specify

②: Stage

S - Single Stage

D - Dual Stage

③: PMD Requirement

1 - 0.05ps Max.

2 - Refer to above Spec.

④: Optical Path Orientation

F - Forward (as indicated above)

B - Backward